

Garden Workbench

Design and Drawing by Barry Humphus

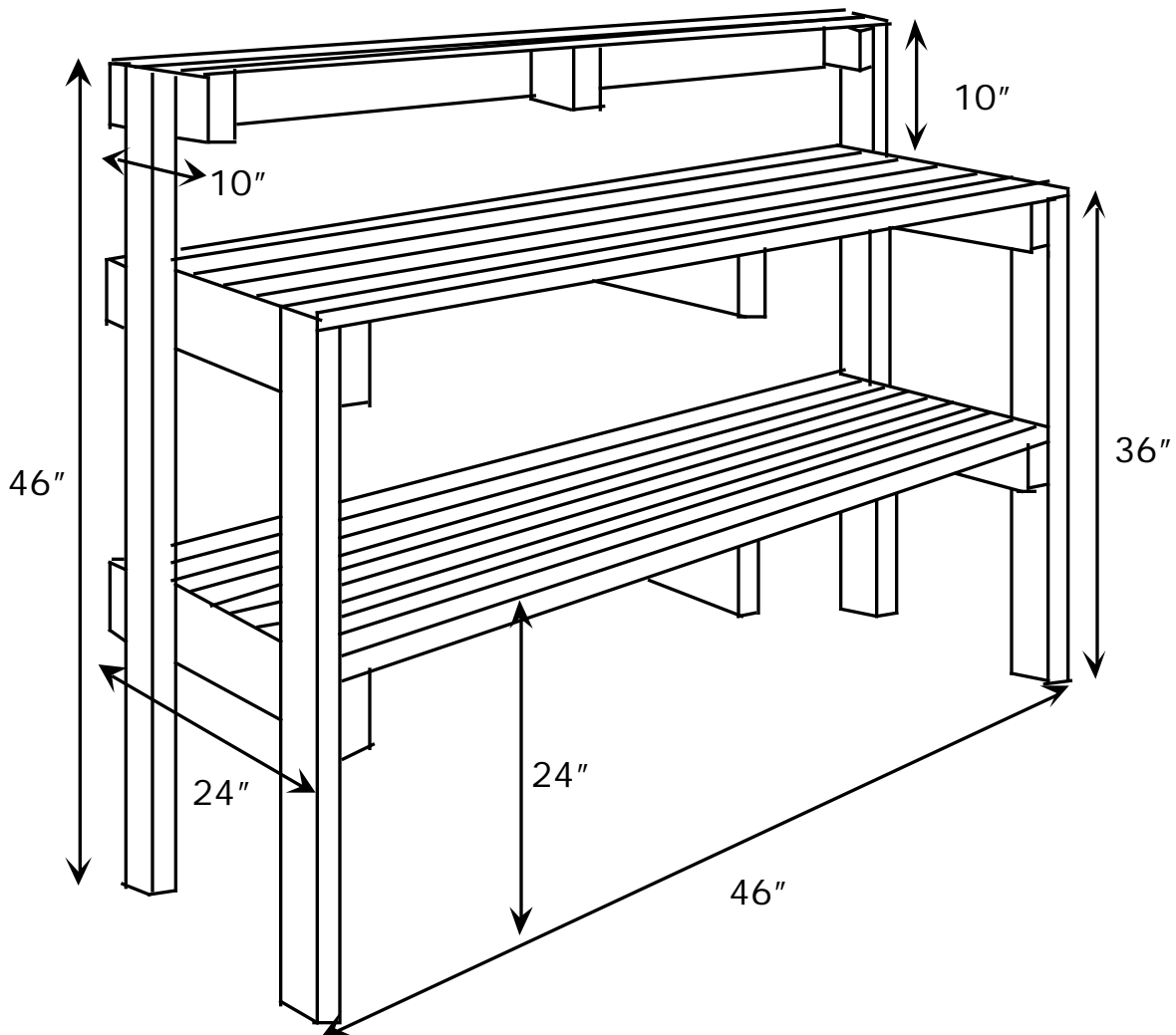

This simple design can be cut and assembled in one afternoon. I used scrap redwood from the rebuilding of my patio cover after the ice storm of 1997. But just about any weather resistant wood will do.

Materials:

- 6 ea 2" x 4" x 46" Pressure Treated Pine (or, redwood, cypress, etc.)
- 2 ea 2" x 4" x 36"
- 6 ea 2" x 4" x 24"
- 3 ea 2" x 4" x 10"
- 23 ea 1-1/2" x 1/2" x 46" slats
- Decking Screws and finish nails

Assemble the lower shelf frames using 1 of the 2" x 4" x 46" and 3 of the 2" x 4" x 24" pieces (with screws) then add 10 of the slats (with nails or screws) to the top of the frame to complete the shelf.

Assemble top shelf using 1 of the 2" x 4" x 46" peices, the three 2" x 4" x 10" pieces and the three remaining slats.

If using treated material or weather resistant wood (cypress or redwood). no finish is necessary.